

DINÂMICA PARA ANALISAR O IMPACTO ECONÔMICO DE UMA AGÊNCIA DE INOVAÇÃO DE UMA INSTITUIÇÃO PÚBLICA

*Systems dynamics to analyze the economic impact of an innovation
agency in a public institution*

DOI: 10.48075/igepec.v25i1.24965

Glauco Oliveira Rodrigues
Henrique Faverzani Drago
Gustavo Chiapinotto da Silva
Eugênio Oliveira Simonetto
Wellington Furtado Santos
Anieli Ebling Bulé

DINÂMICA DE SISTEMAS PARA ANALISAR O IMPACTO ECONÔMICO DE UMA AGÊNCIA DE INOVAÇÃO EM UMA INSTITUIÇÃO PÚBLICA

Systems dynamics to analyze the economic impact of an innovation agency in a public institution

DOI: 10.48075/igepec.v25i1.24965

Glauco Oliveira Rodrigues
Henrique Faverzani Drago
Gustavo Chiapinotto da Silva
Eugênio Oliveira Simonetto
Wellington Furtado Santos
Anieli Ebling Bulé

Resumo: Esta pesquisa apresenta uma análise econômica financeira da Agência de Inovação e Transferência de Tecnologia (AGITTEC) da Universidade Federal de Santa Maria (UFSM). Com a pretensão de contribuir para o conhecimento científico da área, este artigo foi construído tendo um problema de pesquisa definido em verificar quanto a AGITTEC necessita gerar de receita para que possa ser autofinanciada. Foi sistematizado um protocolo de pesquisa de acordo com o método sistemas dinâmicos condizente com o rigor metodológico exigido. A contribuição desta pesquisa se vincula a realizar uma discussão dos resultados favoráveis e benefícios da relação entre a universidade e agência, que podem se estender para melhoria da competitividade das empresas ao apresentarem um melhor desenvolvimento. O estudo serviu para verificar a que apesar das receitas, existe uma grande dependência da agência em relação aos recursos da IES, sendocerca de 90% dos seus custos e despesas.

Palavras-chaves: Dinâmica de Sistemas. Inovação, Transferência de tecnologia, Viabilidade Econômica.

Abstract: *This research presents a financial economic analysis of the Agency of Innovation and Technology Transfer (AGITTEC) of the Federal University of Santa Maria (UFSM). With the intention of contributing to the scientific knowledge of the area, this article was built with a research problem defined in verifying how much AGITTEC needs to generate revenue so that it can be self-financed. A research protocol was systematized according to the dynamic systems method consistent with the required methodological rigor. The contribution of this research is linked to a discussion of the favorable results and benefits of the relationship between university and agency, which can extend to improve the competitiveness of companies by presenting a better development. The study served to verify that despite the revenues, There is a heavy dependence of the agency on UFSM resources, and about 90% of its costs and expenses.*

Keywords: *Dynamic System, Innovation, Technology Transfer, Economic viability.*

Resumen: *Esta investigación presenta una análisis económico y financiero de la Agencia de Innovación y Transferencia de Tecnología (AGITTEC) de la Universidad Federal de Santa María (UFSM). Con la intención de contribuir al conocimiento científico del área, este artículo se construyó con un problema de investigación definido en verificar cuánto necesita AGITTEC para generar ingresos para que pueda auto financiarse. Se sistematizó un protocolo de investigación según el método de sistemas dinámicos acorde con el rigor metodológico requerido. La contribución de esta investigación está vinculada a la realización de una discusión sobre los resultados favorables y beneficios de la relación entre la universidad y la agencia, que se puede ampliar para mejorar la competitividad de las empresas al presentar un mejor desarrollo. El estudio sirvió para comprobar que a pesar de los ingresos, existe una gran dependencia de la agencia en relación a los recursos de la IES, siendo cerca del 90% de sus costos y gastos.*

Palabras claves: *Dinámica de sistemas. Innovación. Transferencia tecnológica. Viabilidad económica.*

INTRODUCTION

Education is the foundation for building a developed nation, the main means of social insertion and transformation, and responsible for personal development, where the individual acquires essential characteristics that will help him / her to become a successful professional. This concept, the educational system seeks new ways of improvement and, in Brazil, it will have a promising future in Higher Education Institutions (HEIs), mainly in the emergence, improvement and growth of companies, institutions, businesses and technologies (LIMA et al., 2015).

In the context related to education, entrepreneurship is taught in higher education, generating the concept of entrepreneurial education, which is therefore identified with the need to create a new professional profile, aimed at channeling the entrepreneurial desire of Brazilians, in that it is up to the HEI and, more specifically, the educators, to contribute to the development of an entrepreneurial education, encouraging students to explore the potential of entrepreneurship in Brazil (CRUZ JR. et al., 2006).

This view of the HEIs, in addressing and encouraging entrepreneurial practices, corroborates the reality of the business market, considering that many organizations are seeking the renewal of their products and services, in order to accompany the rapid development of technology and the globalization of markets, to which consumers are increasingly attentive and demanding as to the quality of products and services offered. In this way, entrepreneurship shows itself, every day, as reinforcement for the improvement of economic and social development in organizations (SOUZA, CARNEIRO and ROLIM, 2014).

Esse fato evidencia que as instituições de ensino superior (IES) não ficaram indiferentes a atual realidade, e procuraram ajustar-se ao mercado, colocando-se a par das políticas sobre o empreendedorismo e tentando dar resposta às exigências das populações. O que são Agências de Inovação? Qual a Lei que obriga toda IF a ter uma agência de Inovação? O que são incubadoras? Quais as vantagens de se ter uma incubadora?

One of the ways of generating response to the demands of the population found by IES was through the implementation of the Agency for Innovation and Technology Transfer (AGITTEC), which was created with the purpose of integrating the management of intellectual property, entrepreneurship and technology transfer. At the institution, being responsible for the two incubators existing in the HEI: Pulsar Incubator and Santa Maria Technological Incubator.

AGITTEC has the rent of the rooms of the incubated companies and royalties provided by the technologies in which IES participated in its development as sources of revenue. However, even with such sources, its costs and expenses are higher than its revenues, therefore AGITTEC does not have the conditions to support itself, and consequently depending on monthly transfers from the Federal University of Santa Maria to maintain itself. In view of the numerous cuts in funds and resource constraints imposed by the federal government, it is questioned what would happen to AGITTEC if the transfers destined to its maintenance were ever extinguished. With this, through the development of a computer simulation model, which allows interested parties to evaluate and analyze different scenarios, the present study has as a central problem to verify how much AGITTEC needs to generate revenue so that it can be self-financed.

To this end, the research problem consisted of the investigation, definition and validation of the variables that make up the simulation model, as well as its design and validation. For the development of the computational model,

techniques from the area of system dynamics were used (DAELLENBACH; MCNICKLE, 2005; GHARAJEDAGHI, 2006). The use of tools in the area of decision support systems seeks to add quality to the decision-making process, because, even today, many decisions about solid waste management are based only on the experience of managers (CHANG and WEI, 2000).

2. RESEARCH METHOD

For the development of this project, computational modeling will be used as methodology, the manipulation of the developed model will be performed through computational simulation. The modeling consists in the elaboration of representations of a real system, called models (ANDRADE et al., 2006). Simulation is the operation on a model of interest (PRADO, 2010), while computer simulation, specifically, is that simulation that uses a computer to be performed (CHWIF; MEDINA, 2015), it is a technique that allows transcribing a real system into a computational environment using resources offered by computers (PRADO, 2010).

The simulation seeks to predict behaviors of the system of interest from reconfigurations and experiments that, normally, cannot be done in the real environment (MARIA, 1997). Longaray (2014) defines a simulation model as the mathematical representation of a physical or abstract system in order to verify the behavior of that system when the values or the ordering of the variables that compose it are changed. A simulation not only provides the best alternative, but a set of viable possibilities for solving the problem, presenting the manager with several scenarios for decision making. From the use of software, the modeler develops as many simulations as necessary until obtaining all the alternatives necessary to supply the acceptable performance for the system being modeled (ANDRADE et al., 2006). The development of the model will be based on the procedures described by Longaray (2014):

- a. Determination of the problem: definition and delimitation of the aspects of interest of the people involved in the decision scenarios for which some action will be taken. In this case, the problem consists in verifying the balance point for AGITTEC to support itself without depending on federal aid;
- b. Elaboration of the model: it consists of determining the technique for solving the problem, delimiting the variables that comprise the model and the scenarios that will represent each research proposal. The elaboration of the model is described in section 3 of this article;
- c. Resolution of the model: in this step the simulation is performed, determining the viable alternatives for the model in question. For this work, three scenarios were defined (current, without public funding and optimistic);
- d. Legitimation of the model: legitimation consists of the decision maker's recognition that the model contemplates his expectations for solving the problem.
- e. Implementation of the solution: the implementation of the model consists of its application in the real environment.

The structure for carrying out the modeling is formed by two main components, stocks and flows. Ford (2009) defines the modeling in systems dynamics as a combination of stocks and flows that use a computational structure to be simulated. Inventories refer to the model-forming variables that are accumulated in the real system (analysis environment) and flows are the decision or policy functions of a system. The theoretical framework used for this research will be exposed below.

2.1 Innovation and Technology Transfer Agency – AGITTEC

The Innovation and Technology Transfer Agency - AGITTEC seeks to expand and intensify institutional initiatives aimed at the dissemination of entrepreneurial culture and education; strengthen technology transfer with a focus on university-business relationships and protect the knowledge and technologies generated by our university community.

AGITTEC originated from the implementation, in 2001, of the Intellectual Property Nucleus - NIT, an organ linked to the Dean's Office of Postgraduate Studies and Research, with the objective of protecting the knowledge generated by the university community. As of 2005, the nucleus was renamed the Nucleus for Innovation and Technology Transfer - NIT, when its mission, objectives and purposes were redefined.

The NITs aim, therefore, to promote interaction between local innovation agents: the protagonists of the Research, Technological Development and Innovation (RD&I) actions and the productive sector, generators and suppliers of information aimed at solving problems. With this, these agents can generate programs, such as, for example, pre-incubation, which basically consists of validating ideas and projects of undertakings taking into account their market viability, be it products or services, with the objective of creating a company that adds high technology and growth potential (SANTOS et al., 2012). And, following NIT, in March 2015 AGITTEC was founded, with the approval of the University Council of IES.

AGITTEC has the following nuclei:

- **Intellectual property (IP):** in order to protect the knowledge generated at the HEI. The analysis takes into account the potential for innovation and technology as a strategy to support innovation management at HEI. The PI operates in the area of registration and protection: Invention (patent); Computer program (software); Integrated circuits topology; Brand; and Cultivar.

- **Technology transfer (TT):** has the responsibility of negotiating technologies, providing support to the researcher in the implementation of partnership projects and promoting the transfer of technology in the HEI. It works by assisting the researcher, being the link between the partners interested in technology. Among the competences, the following stand out: Partnership terms; Infrastructure sharing; Licensing; and Contract for the provision of specialized services.

- **Entrepreneurship:** it is responsible for policies to encourage entrepreneurship, in the creation of technology-based ventures. Manages the Pulsar Incubator and the Santa Maria Technological Incubator - ITSM, both from IES. Its duties are: Pre-incubation program; Incubation program; Support to junior companies of the institution; and Program to encourage innovative entrepreneurship.

2.2 ENTREPRENEURSHIP

The first concept of entrepreneur was introduced in 1725, by the French economist Richard Cantillon. According to the author, an entrepreneur is an agent who buys means of production at certain prices in order to combine them into a new product. Another French economist, Jean Baptiste Say, in 1803, developed the theory that entrepreneurs should be leaders in their environments (SCHUMPETER, 1964).

In the Middle Ages, the term entrepreneur was used to define that person who managed large projects, using resources generally available from the government, and the same did not take risks. Only in the middle of the 18th century did the first signs of a relationship between risk and entrepreneurship arise, in which, through an

agreement between the entrepreneur and the government, ways were established to carry out some type of service or to supply products (DORNELAS, 2014).

The word entrepreneur (entrepeneur) has a French origin and means one who takes risks and starts something new, (DORNELAS 2014).

For Schumpeter (1964, p. 30):

“The entrepreneur is the one who destroys the existing economic order by introducing new products and services, by creating new forms of organization or by exploring new resources and materials. The entrepreneur is best known as the one who creates new businesses, but can also innovate within existing businesses; that is, it is possible to be an entrepreneur within already established companies.”

The entrepreneur has a different thinking from other people, being an individual with a high degree of complexity, unpredictability, whose actions are not always consistent with economic reality. It defines the entrepreneur with personality traits, roles and attitudes that differentiate him from other factors: being innovative; accepting risks and being a developer, implementer and administrator of new ideas (MARTINS, 2007).

What can characterize a successful entrepreneur is a series of elements that make them capable of setting up a successful business. However, there are those who are born with the gift of entrepreneurship, called born entrepreneurs, and there is also the entrepreneur who, influenced by the environment in which he lives, can become an entrepreneur through training, family influence, study and even through his own practice. (OLIVEIRA, 2012).

Brazilian entrepreneurship owes a lot to pioneers from other cultures, driven by extraordinary strength to face adversity. One demonstrates that the market economy can act as a transformative force and not only as a source of profits. Another evidence that every business is the continuation of previous experiences, it is up to you to learn from mistakes, not to repeat them, and with successes, to follow inspiring steps, always with compass, the work ethic (MARCOVITCH, 2006).

In Brazil, it can be said that entrepreneurship is just beginning, but the results already achieved in education indicate that it is the beginning of a silent revolution. According to Bernardi (2003), the first known course in the area came in 1981, at the School of Business Administration of the Getúlio Vargas Foundation, São Paulo, at the initiative of professor Ronald Degen and was called “New business”. It was a discipline of CEAG - Specialization Course in Administration, under the name "Creation of New Business - Training of Entrepreneurs", and today it is one of the mandatory "trails" to be followed by undergraduate students. Later, entrepreneurship teaching was included in the master's, doctoral and MBA courses.

According to Degen (1989), a company will start a new entrepreneurial phase when the growth potential in the business is exhausted and the company wants to continue to grow. For this, it needs to redefine its business. The focus is to change the basic strategic orientation, seeking to increase the company's effectiveness. And according to Degen (1989) and Mintzberg (2010), companies will necessarily go through the following phases:

a) Identify opportunity: Entrepreneurs, in the first stage of a company's growth, accumulate resources and seek to identify business opportunities to start a venture. Perhaps one of the biggest myths about new business ideas is that they must be unique. Whether an idea is unique or not does not matter. What matters is how the entrepreneur uses it, unprecedented or not, in order to transform it into a product or service that makes your company grow. (MINTZBERG, 2010).

b) Diversify: It is the most dangerous, because it tends to cause the company to lose its basic orientation, that is, the culture that informally guides the organization. Therefore, its adoption will only be recommended when the company exhausts its market, in the growth stage, and has very strong reasons for wanting to continue to grow (DEGEN, 1989).

In the view of Mintzberg (2010), there are hundreds of models of strategic planning that help in the beginning and growth of a company, but most of it reduces the same basic ideas, the SWOT matrix, which means identifying the strengths, opportunities, weaknesses and threats that the company may face, and the entrepreneur should divide the clearly outlined steps, articulate each of these steps with many checklists and techniques, with special attention to setting goals at the beginning and preparing budgets and plans operational in the end.

2.3 SYSTEM DYNAMICS

The System Dynamics technique was developed by the American engineer and researcher Jay W. Forrester, based on systemic thinking, which allows the understanding of a system through the identification of the main variables and interrelations that govern its behavior and allows for a more effective action on these systems (FAVORETO, 2005). Jay W. Forrester developed Systems Dynamics to design control systems and later applied them to social, economic and environmental systems. Peter Senge, one of Forrester's disciples, studied the application of Systems Dynamics to organizational problems, publishing the results of his work in the book *The Fifth Discipline* (SENSE, 1994).

System Dynamics uses traditional management techniques, control theory with feedback and computational simulation, allowing a quick visualization of the consequences of system manipulation and decision making. There are two approaches to the representation of cause and effect relationships between the variables of a system, the qualitative and the quantitative approach. The qualitative one is represented by Causal Models, which are diagrams with the purpose of describing a problem situation, that is, they explain the relationships between the variables of the system under study. While the quantitative approach is represented by Stock and Flow Models, which describe the relationships through logical-mathematical equations (VILLELA, 2005).

The dynamics of systems focuses on the behavior of a system in the present, while the prospecting of the scenario focuses on what may occur in the future, based on an understanding of the present (FEATHERSON and DOOLAN, 2013). These authors propose the use of the methodology of scenarios to map the system and the dynamics of systems to specify the causes of the behavior of that system. Randers and Gölluke (2007), on the other hand, question whether systems dynamics can and should be used to prospect for futures. The authors' opinion is that they can and should be used together, as long as the system is well structured.

According to Bueno (2013), systems dynamics is a methodology developed to analyze the cause and effect relationships that certain variables have in a system, be it organizational or social. This methodology is closely linked to systemic thinking and seeks to represent these relationships by studying their evolution over time (Figueiredo, 2009). Based on patterns of behavior, we seek to understand and explain the behavior of isolated variables or together in an existing system (STERMAN, 2000; PIDD, 1998; FORRESTER, 1961).

The main advantages arising from the use of the systems dynamics methodology come from its ability to: a) investigate the relationships between macro and

microstructures and their effects on the system's behavior; b) model and solve real problems, incorporating biological, physical and economic factors; c) improving the performance of a system via the addition of insights or learning, combined with the best use of resources; d) study the flows of material, information and money within economic structures; e) not having a limit of the problems that it can cover, being able to capture situations of balance, imbalance and even chaotic behaviors. In view of these skills, the systems dynamics methodology has been applied in the most diverse areas of knowledge (FIGUEIREDO, 2009).

3. DEVELOPMENT OF THE SIMULATION MODEL

The knowledge produced at Universities can be the answers or solutions to contemporary problems, enabling companies, organized society and the public authorities to apply them, generating and capturing value. To this end, as well as numerous other Universities, IES has an Agency for Innovation and Technology Transfer - AGITTEC, capable of carrying out activities of exploration and transfer of technology, and acting as a facilitator in the process of approximation between the private initiative and Government entities. , researchers and laboratories.

Given this context, and due to the relevance of AGITTEC within the IES, which aims at the development of the institution, a simulation model was sought that would allow interested parties to verify how much AGITTEC needs to increase its own revenues in a period of 10 years so that can self-finance and not depend on public transfers, in view of the instability of the national economy, and the constant cuts in funds for education.

The data used for the development of this model, come from the activities carried out by AGITTEC in the year 2018, to which its sources of income and expenses are specified, as well as the amount provided as a transfer from the federal government, as shown in Table 1.

Table 1 - Data table.

2018	
RECIPES	
Incubator Fees /FATEC	R\$ 51.391,18
Royalty	R\$ 141.936,27
Public Financing	R\$ 1.638.000,00
TOTAL	R\$ 1.831.327,45
EXPENSES	
Office hour	R\$ 13.437,47
Material	R\$ 4.143,64
Outsourced	R\$ 9.487,96
Physical facilities	R\$ 89.540,60
Legal body	R\$ 20.801,05
Servers	R\$ 1.638.000,00
TOTAL	R\$ 1.817.410,72

Source: Prepared by the authors.

The computational model developed is shown in table 1. The central variable of the model is the stock variable called "Transfer" which receives its input value from the "Recipe" flow and has an output value in the "Costs" flow. This set of three variables has the objective of simulating the behavior of the value that may be accumulated, or not, by the institution if it increases or decreases the revenue / cost.

To represent the costs involved in the studied process, we have the auxiliary variable “AGITTECexpenses”, it has six auxiliary variables responsible for entering the values collected directly at the institution, remembering that all values are in reais. The variables are: “Consumables”, “Third Party Legal Services”, “Refund. Use UFSM Infrastructure”, “Indirect Operating Expenses”, “Permanent Equipment and Material” and “Salary”. These variables refer to the costs that the agency has, being divided into costs with expedient, material, outsourced companies, physical facilities, servers and legal staff.

The “Recipe” flow variable, described previously, receives the input values through two auxiliary variables: “Public Investment” and “S A Recipe”. The first represents the investment of the public institution. The variable “S A Recipe” represents the values coming from the private sector and startups. “Private Investment” is the variable responsible for representing the values referring to fees for the use of the institution's physical space, percentages due to the Agency for products / services created by companies linked to incubators. The “Income from financial investments” variable stores investment values.

Figure 1 - Simulation model developed

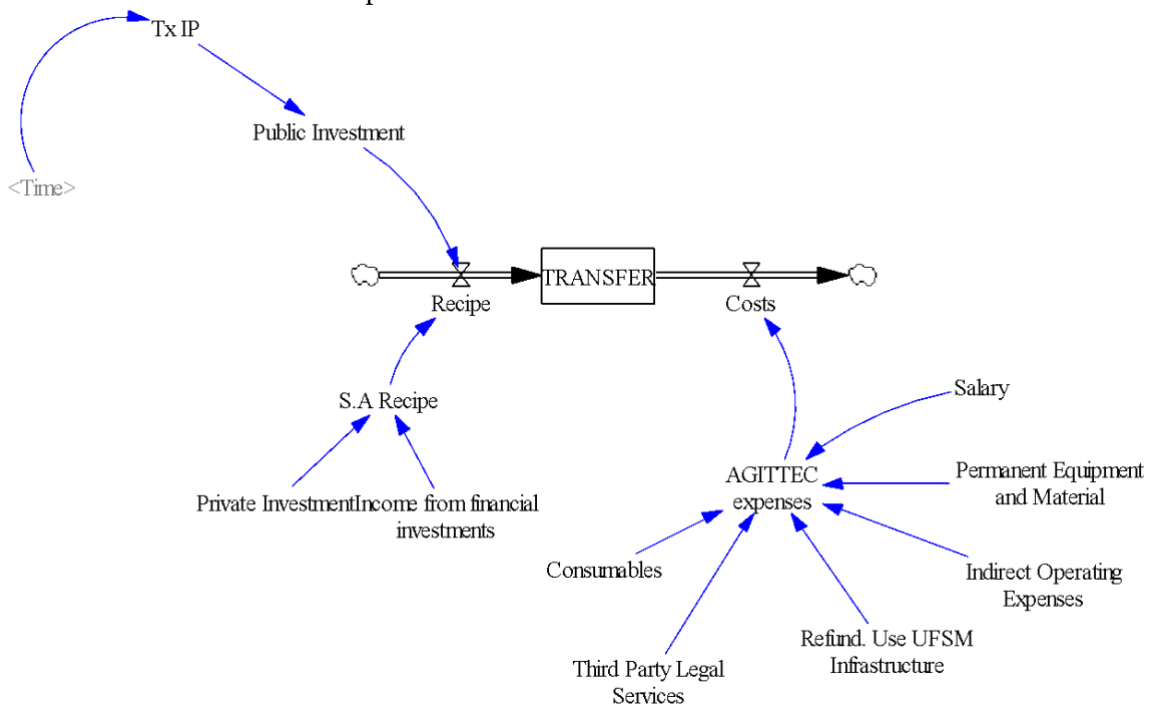

Source: Prepared by the authors.

4 DEVELOPED SIMULATION AND RESULTS

For the modeling developed in this study, three scenarios were generated. Marcial and Grumbach (2005) cite that prospective techniques, such as the generation of scenarios, originated among the military during the Second World War and were used systematically, mainly by the United States of America, to support mechanisms for the formation of warlike strategies.

4.1 CURRENT SCENARIO

The current scenario considered the existing revenues and expenses in the year 2018, as well as the value of the transfer of funds from the government. In other words, this scenario presents a total revenue generation of R \$ 1,831,327.45, of which R \$ 1,680,000 (91.7%) come from public financing. And a total expense of R \$ 1,817,410.72, which generated a symbolic annual profit of R \$ 13,916.73, over the next 10 years.

4.2 PROPOSTSCENARIO

This scenario takes into account that AGITTEC would continue with a fixed annual expense of R \$ 1,817,410.72, but its revenues would no longer receive the contribution from the federal government, that is, they would be only R \$ 193,327.45, which would represent approximately 10.6% of the generated expenses. However, the value will be decreased for 15 years, decreasing the revenue by about 25 percent for each cycle of approximately 4 years.

5. RESULTS

To perform the analysis of the results of the computer simulation, the Vensim software will be used. Vensim has the characteristics of improving real systems, being widely used to develop and analyze models of system dynamics. Through the tools and their extensions, it presents the user with a high quality analysis, with dimensions that absorb and check reality. Different variables can be interconnected, assigning different weights in addition to providing the user with an environment for creating flexible models. Another benefit of the software is that it is free and can be used in classrooms or other educational environments.

After defining the two scenarios for the experimentation of the model, simulations were performed in the Vensim simulator (VENSIM, 2016) on a computer with a Pentium Core i5 processor and 8 Gb of RAM. The simulation run time was in the order of millionths of a second. The simulated time horizon in the experiment was 15 (fifteen) years, but the configuration of this variable is left to the designer / user, as it depends on the analysis to be made.

In this section, the modeling results for the three analyzed scenarios will be presented, as shown in Figure 2, and in how long AGITTEC will reach its equilibrium point, starting with its self-financing.

Figure 2 - Modeling results for the three scenarios analyzed

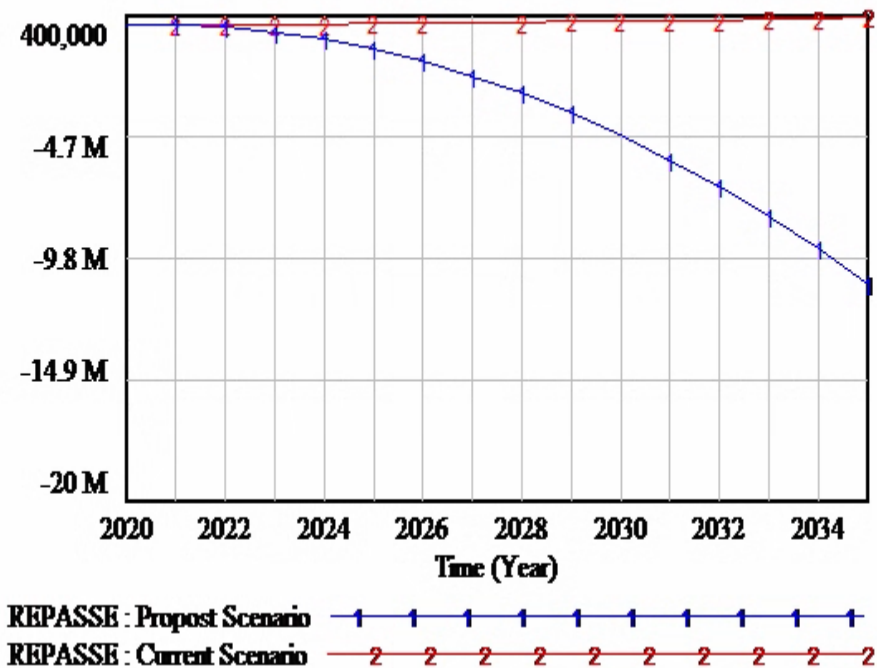

Source: Prepared by the authors.

Current Scenario demonstrates that with the continued financial support of the institution, it is clear that the agency would remain in the blue and also showing a profit of around 6 million reais in fifteen years of accumulated.

In the second scenario, which considers that the company will no longer receive the contribution from public financing, but remaining with the same revenues and costs, AGITTEC would not reach its break-even point in 15 years, resulting in a sharp drop in results, and accumulating constant losses.

It is noted that without the financial support of the federal institution the agency would lose a lot of financial value, would be negative in about 600 thousand reais per year, accumulating a debt of 10 million reais in the year 2035. This data reinforces that even the institution to withdraw investment value little by little, the agency would feel a great financial impact, needing to find other ways to find resources or making its products reach larger markets with higher rates of profit.

6. FINAL CONSIDERATIONS

The objective of the article was to present the development of a computer simulation model to assist in AGITTEC's decision-making process, where it seeks to know how much it needs to generate its own revenue to reach its breakeven point and self-finance its total operation. For the development of the model, variables were used, such as its sources of revenue, its costs and expenses, and the amount subsidized by the government.

Through the results generated by the model, the parties interested in the study will be able, for example, to see how much AGITTEC would need to increase its own revenues (fees with incubators, and the royals to which it is entitled), so that it does not depend on public funding for operate. With this, it could establish annual goals so

that it gradually increases its revenues, which consequently would increase its role of collaborating and fostering innovation and technology transfer, making the intermediation between public and private institutions more frequently.

“For the development of the simulation model, the concept that Systems Dynamics models are composed of stock, flow variables, both endogenous variables, was taken into account. One of the central objectives of the Systems Dynamics methodology is to have a model that can simulate real behavior. That is, the source of problems in a system is an inherent part of the model developed.”

The Systems Dynamics methodology helped to map the structures of the developed system, seeking to examine its interrelation in a broad context. Through the developed simulation, the applied dynamics intends to understand how the system in focus evolves over time and how changes in its parts affect its behavior. From this understanding, it was possible to diagnose and predict the system, in addition to making it possible to simulate more scenarios over time.

Two scenarios were generated, using data collected through interviews with stakeholders and bibliographic review. The results obtained are consistent with reality, and can help the institutions involved to be able to plan, if they deem it necessary, the functioning of AGITTEC without depending on public funding.

The study served to verify the great dependence that AGITTEC has in relation to the federal government, where for it to be able to maintain itself, it needs that it bears more than 90% of its costs and expenses.

In times of economic reorganization on the part of the country, to which many cuts and contingencies of funds are constantly announced by the government, it is thought that it would be at least prudent for AGITTEC to think about self-support, not expecting, who knows, no longer have federal funds, and force yourself to stop operating.

REFERENCES

BUENO, N. P. **Identificando mudanças de regimes sistêmicos em processos econômicos: um procedimento baseado na abordagem de dinâmica de sistemas.** Economia e Sociedade, 22(1), 77-106, 2013.

CRUZ JR., J. B.; ARAÚJO, P. da C.; WOLF, S. M.; RIBEIRO, T. V. A. **Empreendedorismo e educação empreendedora: confrontação entre a teoria e prática.** Revista de Ciências da Administração, v. 8, n. 15, p. 1-22, jan./jun. 2006.

DEGEN, R. **O Empreendedor: fundamentos da iniciativa empresarial.** São Paulo: McGraw-Hill, 1989.

DORNELAS, J. C. A. **Empreendedorismo: transformando ideias em negócios.** 5. ed. Rio de Janeiro: Empreende/LTC, 2014.

FEATHERSTON, C. R.; DOOLAN, M. **Using system dynamics to inform scenario planning: a case study.** Proceedings of International Conference of the System Dynamics Society, 30, St. Gallen, Switzerland, 2013.

FIGUEIREDO, J. C. B. D. **Estudo da difusão da tecnologia móvel celular no Brasil: uma abordagem com o uso de Dinâmica de Sistemas**. Produção, 19(1), 230-245, 2009.

FORRESTER, J. W. **Industrial dynamics**. Cambridge: MIT Press, 1961.

LIMA, E.; LOPES, R. M. A.; NASSIF, V. M. J.; SILVA, D. **Ser seu próprio patrão? Aperfeiçoando-se a educação superior em empreendedorismo**. Revista de Administração Contemporânea, v. 19, n. 4, p. 419- 439, jul./ago. 2015.

MARCOVITCH, J. **Lições do pioneirismo no Brasil**. HSM Management, São Paulo, v. 1, n. 32, julho-agosto, 2006.

MARTINS, P. E. **O empreendedor do sertão**. HSM Management, São Paulo, v. 1, n. 28, março-abril, 2007.

MINTZBERG, H. **Safari de estratégia: um roteiro pela selva do planejamento estratégico**. 2ª Ed. Porto Alegre: Bookman, 2010.

OLIVEIRA, F. M. **Empreendedorismo: teoria e prática**. Instituto de pós graduação IPOG, Goiânia, Maio 2012.

SENGE, P.M. **“The fifth discipline:the art and practice of the learning organization”**, First Paperback Edition. Nova Iorque: CurrencyDoubleday, 1994.

VILLELA, P. R. C. **“Introdução à Dinâmica de Sistemas”**, Universidade federal de Juiz de Fora – UFJF, 2005.

PIDD, M. **Computer simulation in management science**.Lancaster: John Wileys& Sons, 1998.

FAVORETO,R.S. **“Estratégias de Planejamento Empresarial: Tratamento de Incertezas de uma Empresa de Geração no Sistema Elétrico Brasileiro”**, Dissertação de Mestrado, Universidade Federal do Paraná – UFPR, 2005.

RANDERS, J.;GOLUKE, U. **Forecasting turning points in shipping freight rates: lessons from 30 years of practical effort**. System Dynamics Review, 23(2), 253-284, 2007.

SANTOS, N. A. J.; MASSENA, P. B.; CAMPOS, C.; CARVALHO, L. L. **Proposta de Programa de Pré-Incubação e Incubação de Empresas na Unidade Operacional de Rio das Ostras da Rede de Incubadoras da UFF**. In: Simpósio de Excelência Em Gestão e Tecnologia, IX, 2012, Rio de Janeiro, RJ. Anais...Rio de Janeiro, 2012.

SCHUMPETER, J. A. **História da análise econômica**. Rio de Janeiro, RJ : Fundo de Cultura, 1964.

STERMAN, J. D. **Business dynamics:systems thinking and modeling for a complex world**. New York: McGraw-Hill, 2000.

Submetido em 8/10/2020
Aprovado em 20/12/2020

Sobre o(s) Autor(es):

Glauco Oliveira Rodrigues

Possui graduação em Redes de Computadores pela Universidade Federal de Santa Maria (2014). Mestrado em Administração pela Universidade Federal de Santa Maria (2016) e Doutorando pela Universidade Federal de Santa Maria. Tem experiência na área de Ciência da Computação, com ênfase em Redes de Computadores, participante de pesquisa na área de Sistemas de Informação, Pesquisa Operacional e Sustentabilidade Ambiental, atuando principalmente nos seguintes temas: modelagem de sistemas complexos e ambientais. Email: glauco10@redes.ufsm.br.

Henrique Faverzani Drago

Doutorando em Administração pelo PPGA da UFSM (2019-2022), na linha de pesquisa de Gestão de Pessoas e Comportamento Organizacional. Mestre em Administração pelo PPGA da UFSM (2017-2018), na linha de pesquisa Gestão de Pessoas e Comportamento Organizacional. Possui graduação em Administração de Empresas pelo Centro Universitário Franciscano - UNIFRA (2008). Tem experiência na área de Administração, com ênfase em Administração de Empresas, empreendedorismo, inovação, cooperativismo e finanças. De 2010 até 2017 foi gerente de relacionamento empresas do Banco Itaú. Atuante como pesquisador no Grupo de Pesquisa em Mudanças Organizacionais, Inovação, e Comportamento Organizacional MUTARE (PPGA/UFSM), com o foco específico nos seguintes temas: Empreendedorismo, Mudanças, Gestão Estratégica, Gestão de Pessoas e Comportamento Organizacional. Email: henrique_fd@yahoo.com.br

Gustavo Chiapinotto da Silva

Graduado em Engenharia Elétrica pela Universidade Federal de Santa Maria (2002) e Mestre em Engenharia de Produção pela Universidade Federal de Santa Maria (2005). Atualmente no cargo de Diretor do Centro de Processamento de Dados, unidade de Tecnologia da Informação da Universidade Federal de Santa Maria. Email: gchiapinotto@ufsm.br

Eugênio Oliveira Simonetto

Possui graduação em Análise de Sistemas pela Universidade Católica de Pelotas (1995), mestrado em Ciência da Computação pela Pontifícia Universidade Católica do Rio Grande do Sul (1998), doutorado em Administração (Área: Sistemas de Informação e Apoio à Decisão) pela Universidade Federal do Rio Grande do Sul (2004) com reconhecimento pela Universidade do Minho (Portugal) e estágio em Produção e Sistemas na Universidade do Minho (2016). Atualmente é professor associado no Departamento de Ciências Administrativas da Universidade Federal de Santa Maria (UFSM). Tem experiência nas áreas de modelagem de sistemas de apoio a decisão e gestão da produção. Email: eosimonetto@gmail.com

Wellington Furtado Santos

Graduado em Administração de Empresas, Especialista em Economia, Mestre em Economia Empresarial pela Universidade Cândido Mendes do Rio de Janeiro e Doutor em Administração na linha de Pesquisa: Economia e Finanças pela Universidade Federal de Santa Maria - UFSM. Tem realizado Pesquisas nas áreas de Gestão Pública, Economia e Mercado Financeiro. Professor em regime de dedicação exclusiva do Instituto Federal Farroupilha no Campus de São Vicente do Sul. Email: wellington.furtado@gmail.com

Anieli Ebling Bulé

Doutoranda em Administração pelo Programa de Pós-Graduação em Administração da Universidade Federal de Santa Maria - PPGA/UFSM na linha de Sistemas e Mercados. Mestre pelo Programa de Pós-Graduação em Administração da Universidade Federal de Santa Maria - PPGA/UFSM na linha de pesquisa Sistemas, Estruturas e Pessoas. Administradora

graduada pela Universidade de Cruz Alta - Unicruz. Atuou como Docente do Instituto Avanza - Capacitação Profissional, nos Módulos de Gestão Empresarial e Gestão de Recursos Humanos. Atuou como sócia proprietária da Bulé - Madeiras Compondo Ambientes, empresa do ramo moveleiro e madeireiro situada em Cruz Alta - RS. Possui experiência em Gestão Empresarial. Atualmente é Docente do Ensino Básico, Técnico e Tecnológico no Instituto Federal de Educação, Ciência e Tecnologia Farroupilha - IFFar - Campus Frederico Westphalen/RS, nas áreas de Marketing e Empreendedorismo. Email: anieli.bule@hotmail.com